

IHSAA POST-SEASON INDIVIDUAL SECTIONAL AND DISTRICT WRESTLING TOURNAMENT MANUAL

CLASSIFICATION OF TEAMS

There are three classifications in wrestling. The largest 64 schools with wrestling programs will be Class 3A; the next 96 largest will be Class 2A; and the remainder of the schools with wrestling program will be Class 1A.

TOURNAMENT DATES & STARTING TIMES

SECTIONALS: 1A & 2A - February 4, 2017, 12:00pm.

DISTRICTS: 1A, 2A & 3A - February 11, 2017, 12:00pm.

The tournament manager will determine what time the spectator doors will open and when participating schools' personnel are allowed to enter the building.

TIME SCHEDULES FOR SECTIONAL AND DISTRICT WRESTLING TOURNAMENTS

Sectional and district wrestling shall take place during one session, with one 20-minute break taken at a time determined by the meet manager.

The following is a sample time schedule for 1A & 2A sectional, and 3A district, tournaments; however, tournament managers will make the final determination as to the final schedule.

Round 1: First-round matches.

Round 2: Semifinal matches & first round consolation matches.

Round 3: Championship finals and front-side consolation matches (*losers of semi-finals*) in each weight class will be wrestled simultaneously. **EXAMPLE:** *106-lb. championship final and 106-lb. front-side consolation on two mats at the same time. Continue with this procedure through the 285 lb. weight class so losers of the championship final and front-side consolation will have a similar amount of rest in the event they wrestle for true second place.*

Round 4: Fifth-place matches.

Round 5: Consolation final matches for determining true second place, when needed.

This sample schedule should expedite wrestling, as far as wrestlebacks and consolation matches are concerned, and allow competitors as much equity as possible regarding rest between matches.

In class 1A and 2A district tournaments, the break, if any, shall be determined by the tournament manager, keeping in mind the national rule requiring 45 minutes of rest between matches.

ADMISSION

SECTIONAL TICKET PRICES: Adults & Students (K-12) \$6.00

DISTRICT TICKET PRICES: Adults & Students (K-12) \$6.00

There are no 'pass outs' for IHSAA events. Anyone leaving the arena must purchase another ticket to return.

IHSAA-IGHSAU SPONSORED EVENT TICKET POLICY (ADOPTED, 2004)

The Boards of the Iowa Girls High School Athletic Union and the Iowa High School Athletic Association are concerned with the accounting procedures used by member schools during the IGHSAU and IHSAA sponsored tournament events. The Boards of both of your organizations have taken formal action, adopting a policy/procedure that must be used by schools serving as IGHSAU and IHSAA tournament hosts.

The procedure to be followed is as follows:

1. Collect the money for the ticket(s) sold.
2. Tear ticket(s) off the roll in consecutive order and then tear the ticket(s) in half or have the person at the entrance door tear the ticket(s) in half and deposit them in a receptacle, there upon the spectator may enter the tournament venue.
3. The IGHSAU and IHSAA also have adopted policies that when tickets are sent, a verification slip is signed and returned to the respective organization, acknowledging the number of tickets received for sale. The Boards of the IGHSAU and IHSAA have instructed the administration of the organizations to notify schools that if they do not desire to follow the adopted ticket policy/procedure, they should not accept tournament invitations or that schools not adhering to the new policy of ticketing during tournament events, not be used as tournament sites in the future.

COMPLIMENTARY ADMISSIONS TO SECTIONAL AND DISTRICT TOURNAMENTS

The following people receive complimentary admission to sectional and district tournaments:

1. The participating wrestlers from each school whom actually weigh-in, the head coach(es), **three assistant coaches**, and two team managers.
2. A maximum of six cheerleaders per participating school, if in uniform, and their chaperone.
3. Any school administrator with a school administrator pass and ONE guest.
4. Any current, or former, IHSAA Board of Control member presenting a lifetime pass, and their respective spouse.
5. Any member of the host school's Board of Education and spouse.
6. Bona fide members of the press, radio, and television media attending in the capacity of reporter and/or photographer. ***(This does not include a representative of a school paper, yearbook, etc.)***
7. One team bus driver for each participating school.

ADVANCING FROM SECTIONAL AND DISTRICT COMPETITION

For each of the sixteen Class 1A and 2A sectional tournaments, the champion and runner-up wrestler in each weight class will advance to the district tournaments. There will be eight Class 1A & 2A district tournaments with four wrestlers per weight class in each district tournament.

There will be eight Class 3A district tournaments with a maximum of eight wrestlers in each weight class. Each champion and runner-up from the 1A, 2A, and 3A district tournaments will qualify to the state meet.

Sectional Champion or Runner-Up Unable to Advance to District Competition

If for some reason (injury, illness, ineligibility, etc.) a Class 1A or 2A wrestler who has qualified for the district tournament cannot compete, the athletic director from

the wrestler's school should call the IHSAA immediately. **NOTIFICATION REGARDING INJURY OR ILLNESS MUST BE MADE TO THE DISTRICT MANAGER BY 10:00AM ON SATURDAY OF DISTRICT COMPETITION IN ORDER FOR THE 3RD PLACE SECTIONAL WRESTLER TO HAVE THE OPPORTUNITY TO ADVANCE TO DISTRICT COMPETITION.** The district manager will then contact the IHSAA office. When this occurs, the 3rd-place finisher from that sectional will advance to district competition. If a sectional champion is unable to compete in the district tournament, the runner-up from that sectional will take the champion's place on the district bracket and the 3rd-place wrestler from that sectional will take the runner-up place on the bracket. If a runner-up is unable to compete, the 3rd-place wrestler from that sectional will take the runner-up's place on the bracket. **In no case will a 4th-place sectional finisher advance to the district tournament.** If the 1st-place, 2nd-place, or 3rd-place wrestlers cannot compete in 1A/2A districts, or at the state tournament in classes' 1A-3A, the opposing wrestler, who is present and has made weight for that weight class, is awarded a forfeit and two advancement points. **Failing to make weight is not a legal reason for allowing a third-place finisher from the sectional tournament to be entered into the district tournament. If the sectional champion or runner-up misses weight at the district meet, that spot becomes a forfeit.**

District Champion or Runner-Up Unable to Advance to Individual State Tournament

If for some reason (injury, illness, ineligibility, etc.) a Class 1A or 2A wrestler who has qualified for the individual state tournament cannot compete, the athletic director from the wrestler's school should call the IHSAA immediately. **NOTIFICATION REGARDING INJURY OR ILLNESS MUST BE MADE TO THE ATHLETIC ASSOCIATION BY 9:00PM WEDNESDAY BEFORE THE INDIVIDUAL STATE WRESTLING TOURNAMENT FOR ANOTHER WRESTLER TO ADVANCE TO THE STATE TOURNAMENT. IF THE INJURED/ILL WRESTLER IS A MEMBER OF A TEAM PARTICIPATING IN THE STATE DUALS THE TOURNAMENT MANAGER WILL DETERMINE THE DEADLINE FOR ADVANCEMENT OF THE 3RD PLACE DISTRICT WRESTLER.** In no case will a 4th-place district finisher advance to the state tournament. If the 1st-place, 2nd-place, or 3rd-place wrestlers cannot compete in the state tournament, the opposing wrestler, who is present and has made weight for that weight class, is awarded a forfeit and two advancement points. **Failing to make weight is not a legal reason for allowing a third-place finisher from the district tournament to be entered into the state tournament. If the district champion or runner-up misses weight at the state meet, that spot becomes a forfeit.**

AWARDS

In sectional & district competition, individuals placing 1st – 3rd in their respective weight classes will be awarded medals. Individual champions will also receive the IHSAA wall chart for their weight class. In addition, the district team champion will receive an IHSAA District Wrestling Championship banner. **Wrestlers participating in the awards ceremonies are to wear only school-issued attire.**

BANNERS, SIGNS, HOOPS, CONFETTI, ETC., PROHIBITED

The Board of Control of the IHSAA prohibits spectators from displaying any banners or signs, artificial noisemakers, as well as, the use of confetti, etc. Cheerleaders are prohibited from using a paper hoop designed for athletes to run through when coming onto the mat. *(This regulation is in effect for sectional & district tournaments, as well as, the state tournament.)*

BOARD POLICY REGARDING SPECTATOR DRESS AT STATE TOURNAMENT SERIES CONTESTS

Shirts and shoes are required attire for spectators in attendance at all indoor IHSAA-sponsored athletic events.

BLOOD BORNE PATHOGENS

Host schools are responsible for the necessary disposable supplies and personnel for cleaning blood from the mat or other areas of the facility. Participating schools are responsible for the cleaning of blood and other body fluids from their own athletes, and for using universal precautions when doing so.

BROADCASTING

Click here - <http://www.iahsaa.org/wp-content/uploads/2017/01/MEDIA-POLICIES-FOR-IHSAA-TOURNAMENTS-2.pdf> for the "IHSAA Policy Regarding Rebroadcasting /Broadcasting of IHSAA Events".

BYES, DEFAULTS & FORFEITS AT SECTIONAL AND DISTRICT TOURNAMENTS

Rule 10-3 in the NFHS Wrestling Rule Book addresses tournament brackets and byes. The following are examples explaining how team points should be awarded for a bye, forfeit, or default.

Example 1: Wrestler #1 is scheduled to wrestle #2 in the first round of the 1A/2A sectional, or 3A district, tournament. Wrestler #1 makes weight and is ready to wrestle, but wrestler #2 fails to make weight. Wrestler #1 receives a bye, is awarded two advancement points and advances to the next round. *No forfeit is awarded because wrestler #2 is not officially entered in a 1A/2A sectional or 3A district tournament because they did not make weight at the weigh-in.*

Example 2: Wrestler #1 is scheduled to wrestle #2 in the first round of the 1A/2A sectional or 3A district tournament. Both wrestlers make weight. Wrestler #2 becomes ill, or injured, and is unable to wrestle. Wrestler #1 is declared the winner by default, is awarded two points for the default, two advancement points, and advances to the next round of competition. *If this occurs during the consolation round, only one advancement point is scored.*

Example 3: Wrestler #1 is scheduled to wrestle #2 in the first round of a 1A/2A district tournament, or at the state meet in any class. Wrestler #1 fails to make weight. Wrestler #2, who made weight, wins by forfeit and is awarded two points for the forfeit and two advancement points because all wrestlers are officially entered in the tournament through qualification at the sectional or district tournament.

Example 4: Wrestler #1 and wrestler #2 are competing in a match. Wrestler #2 becomes injured through NO illegal action by #1 and is unable to continue. Wrestler #1 wins the match by default and is awarded two points for the default, plus two points for advancement, if the match is part of the championship bracket. *If this match occurs during the consolation round, only one advancement point would be scored, in addition to the two points for the default.*

CHARITABLE CONTRIBUTIONS AND SOLICITATIONS

Tournament managers may be confronted with various requests pertaining to donations and contributions to organizations that rely upon this method or system of financing their programs. The Board of Control prohibits the passing of hats, receptacles, blankets, etc., inside the gymnasium at any IHSAA-sponsored tournament for the purpose of collecting any contributions to any group or organization. The Board of Control does not object to placing a receptacle in the vestibule or lobby of the gymnasium where the people may deposit their contributions, provided this arrangement meets with the approval of the local tournament manager.

CERTIFIED WEIGHT

Wrestlers who have NOT certified their minimum wrestling weight class by making scratch weight at least one time during the regular season in the weight class at which they are competing must make scratch weight at the Class 1A or 2A sectional, or 3A district, tournaments.

CHEERLEADERS

Each school participating in a sectional or district wrestling tournament is allowed a maximum of 6 cheerleaders (NO MASCOTS), if they are wearing a BONA-FIDE SCHOOL ISSUED OR APPROVED CHEERLEADING uniform (**NO T-shirts and shorts**) and one chaperone to be admitted free-of-charge. Additional information for cheerleaders is provided on the IHSAA web site under the "Wrestling" heading or at this link - <http://www.iahsaa.org/wp-content/uploads/2017/01/Sectional-District-Regional-Dual-Team-Wrestling-17.pdf>

CLEANING THE WRESTLING MATS

To reduce the risk of communicable skin conditions, it is recommended that sectional and district hosts clean the wrestling mats with disinfectant cleaner between rounds, as necessary.

COMMUNICABLE SKIN CONDITIONS

Coaches who have a wrestler(s) with a suspect skin condition are required to have the completed IHSAA Skin Condition Report Form indicating the condition is not communicable on the date of competition with them in order for the wrestler(s) to compete. COACHES MUST PRESENT THE FORM TO THE MEET MANAGER OR LEAD OFFICIAL AT THE WEIGH-INS. If a **designated on-site medical professional** (*Medical Doctor, Doctor of Osteopathic Medicine, Doctor of Chiropractic, Physician's Assistant, or Advanced Registered Nurse Practitioner*) is present at the weigh-ins, he or she has the authority to rule on any suspect communicable skin conditions. This **designated on-site medical professional** has the authority to allow, or deny, participation regardless of what is indicated on the IHSAA Skin Condition Report Form.

CONCESSIONS, PROGRAMS & T-SHIRTS

Each tournament manager is responsible for the sale of concessions, programs, T-shirts and any other items they may want to have available for sale at their sectional and district tournament.

CONDUCT COUNTS

Conduct Counts rules are in effect for all post-season tournaments. Each host school should have Conduct Counts posters for the posting of these rules.

ENTRY REGULATIONS, VERIFICATION OF ENTRIES, & WEIGH-IN FORMS

Wrestlers cannot be entered in a weight class lower than that permitted by their body composition assessment or descent plan.

Final entries, including changing any entries or the weight class at which wrestlers will weigh in, must be made with the tournament manager or his/her designee before the weigh ins begin.

The declaration of the weight class in which each wrestler will compete must be made with the tournament manager or his/her designee before the last 285# wrestler steps off the scale.

ENTRIES: Entry into the Class 1A & 2A Sectional and 3A District Tournaments will be done through TrackWrestling. All coaches will receive an email from TrackWrestling the Monday before their 1A/2A Sectional or 3A District meet with complete instructions on how to enter wrestlers into their tournament. The entry deadline is 12:00pm, noon, on the Thursday before 1A/2A sectionals and 3A districts. **Coaches should enter the (ONE) wrestler in each weight class whom they believe will be the actual competitor. TWO wrestlers per weight class may be listed on the weigh-in form, but only one contestant per school may compete in each weight class. FINAL entries and the declaration of the weight class in which each wrestler will compete MUST be made BEFORE the conclusion of weigh ins.** NFHS rules allow a wrestler to compete one weight class above the weight class for which he actually weighs in; as long as the coach notifies the tournament manager by the verification deadline which is the conclusion of weigh ins. **Coaches may verify entries privately with the tournament manager, or his/her designee, if they choose. ENTRIES WILL NOT BE RELEASED TO SCHOOLS PRIOR TO THE CONCLUSION OF WEIGH INS.**

WEIGH-IN FORMS: Coaches must enter their wrestlers into the Trackwrestling On-Line weigh-in form for their Class 1A, 2A Sectional, or 3A District Meets, just as they have during the regular season. This form will show each wrestler's lowest eligible weight class for the tournament, according to their descent plan, and **if they receive the growth allowance. Coaches should also bring copies of the actual, paper weigh-in forms from each regular season meet.** These actual weigh-in forms are to be presented to the Meet Manager, or his/her designee, if any questions arise regarding the weight class at which a wrestler is qualified to weigh-in. **Any wrestler competing in the tournament at a weight class for which he is NOT qualified will be disqualified from the tournament and will not advance out of the tournament.** *Class 1A and 2A district qualifiers, and state qualifiers in all classes, do not need to be entered into the TrackWrestling Online weigh-in form because they must weigh-in for the same weight class at which they competed during qualifying tournament.*

INTRODUCTION OF WRESTLERS AT 1A & 2A DISTRICTS

If a 1A or 2A district host would like to introduce the four wrestlers in each weight class they may do so immediately before wrestling begins at 12:00pm. As a courtesy, the participating schools should be notified in advance or during the weigh ins or coaches meeting.

LENGTH OF PERIODS

ALL matches during post-season competition (championship and consolation) will consist of three, 2-minute periods (2-2-2).

OFFICIALS FOR POST-SEASON TOURNAMENTS

Officials for all post-season tournaments will be assigned and paid by the Athletic Association. Each tournament host will be notified as to the officials assigned to their tournament.

PAIRINGS, BRACKETS, & SEEDING

Pairings for Class 1A, 2A sectional, and 3A district, tournaments will be conducted under the supervision of the Tournament Manager, or his/her designee. The rules provide for seeding, if coaches are in general agreement that seeding for a particular weight class should take place. The tournament manager will determine the starting time for the seeding meeting. The seeding meeting may begin **before** all weight classes have weighed in so as not to delay the start of the meet. **HOWEVER, coaches MUST declare the weight classes in which ALL of their wrestlers will compete BEFORE the conclusion of weigh ins.** If no seeding takes place, the wrestlers will be placed on the bracket by random draw. Complete pairing information appears in this manual and rule 10-3 of the NFHS Wrestling Rule Book.

All seeding shall be done according to Rule 10.3 of the current NFHS Wrestling Rule Book. The seeding feature in TrackWrestling will be used for initial seeding, with final changes made during the seeding meeting at 1A/2A sectional and 3A district meets. The tournament management, and/or the head coaches as a group, should establish criteria for seeding prior to commencing the actual seeding meeting. If the coaches cannot agree on the number of wrestlers to seed, or who to seed, placement on the bracket for all wrestlers in the affected weight class(es) will be drawn by lot. There are no mandatory criteria for determining seed positions or the number of wrestlers to seed. Consideration should be given to following when determining seed placement:

- Varsity competition only;
- Head-to-head competition;
- Records against common opponents (*byes do not count as a win*);
- Returning sectional, district, state champion or runner-up in the same weight class;
- Seeding only winning records;
- Seeding only those wrestlers who have wrestled a minimum number of matches;
- Exceptional record against acknowledged strong opposition;
- Best overall record.

A seeded wrestler shall have the same opportunity for a bye as any other contestant, or byes may be placed by mutual consent.

CLASS 1A/2A SECTIONAL & 3A DISTRICT WRESTLING BRACKETS

Seed all weight classes according to NFHS rule 10-3. (*Numbers on the bracket in parentheses indicate seeded wrestlers.*)

- 1) **As per the Wrestling Coaches Advisory Committee recommendation, eight person brackets will be used for ALL 1A & 2A sectional and 3A district meets, regardless of the number of wrestlers competing in a weight class. Wrestlers on championship brackets with less than 8 wrestlers and consolation brackets with**

less than 4 wrestlers will receive byes until they reach a bracket with an opponent.

- 2) If byes are necessary, draw for them according to NFHS rule 10-3.
- 3) After any byes are drawn, place the remaining wrestlers by draw.
- 4) Read the information under the heading "SUMMARY OF 1A & 2A SECTIONAL AND 3A DISTRICT WRESTLING PLACE POINTS AND ADVANCEMENT POINTS" for additional information.

(2 Advancement points on the championship side of the bracket & 1 advancement point on consolation side of the bracket.)

CLASS 1A & 2A Sectional/3A District Wrestling

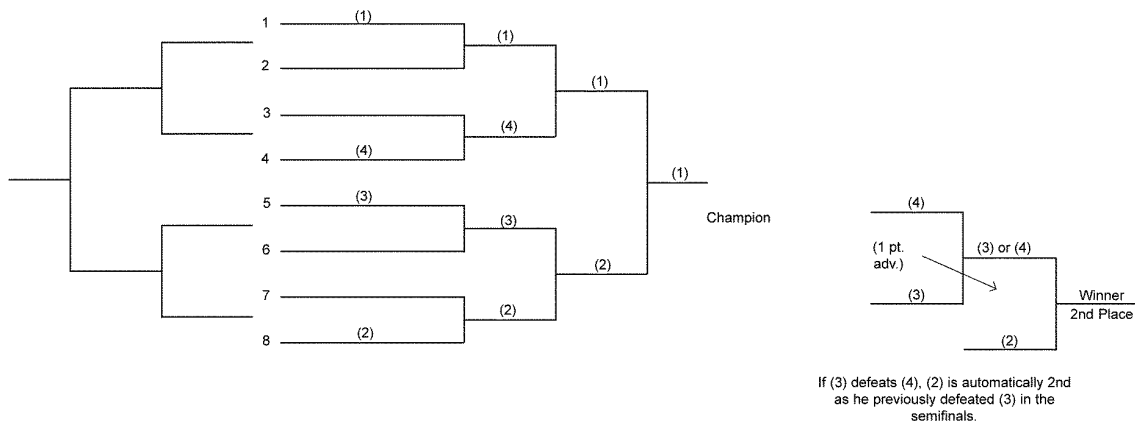

CLASSES 1A & 2A DISTRICT TOURNAMENT BRACKETS

The winner and runner-up in each weight class from each Class 1A and 2A sectional tournament qualify for district competition. Pairings for Class 1A & 2A District Tournaments are predetermined and pair the champion from one sectional in each weight class against the runner-up from the other sectional represented at the district tournament. The two sectional tournament sites competing at the district site will be listed alphabetically. The first sectional site in the alphabetical list, according to the IHSAA Directory, will be "A," and the second site alphabetically will be "B." All weight classes will be paired as follows:

- A-1 (champion) vs. B-2 (runner-up)
- A-2 (runner-up) vs. B-1 (champion)

(2 Advancement points on the championship side of the bracket & 1 advancement point on consolation side of the bracket.)

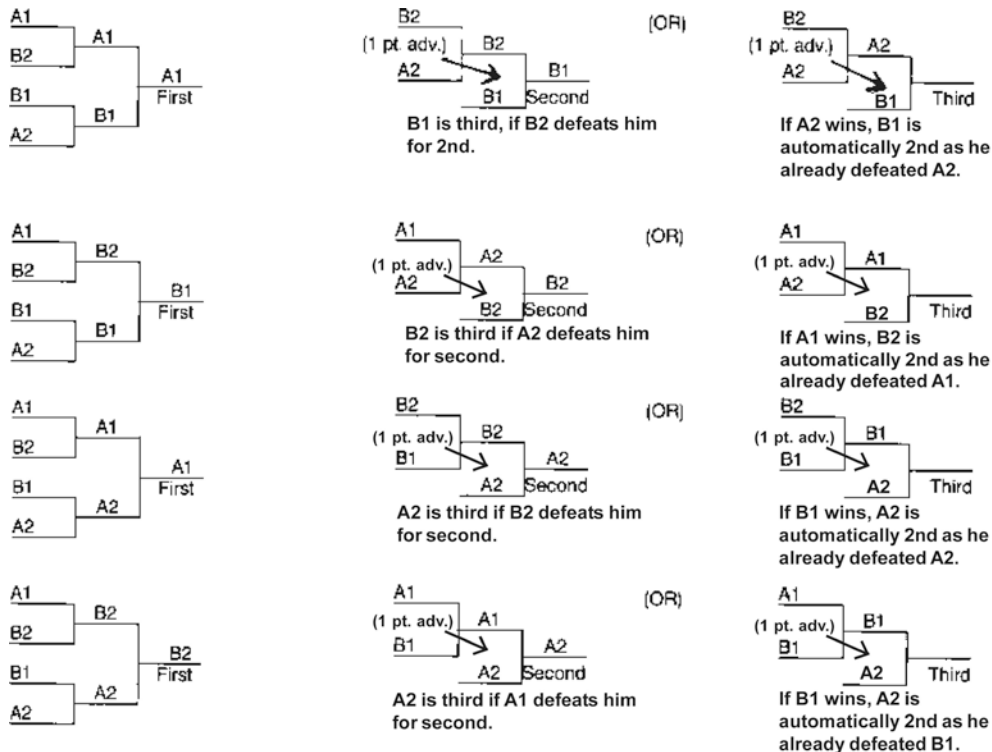

PRAYER AT IHSAA-SPONSORED EVENTS

IHSAA Board of Control action from February 24, 2001 states, "Prayer shall not be permitted at IHSAA-sponsored events in accordance with the Supreme Court ruling on June 17, 2000". (Supreme Court of the United States, Santa Fe Independence School District vs. Jane Doe, #99-62).

REPORTING RESULTS

Individual and team results will be reported through TrackWrestling.

SUMMARY OF 1A & 2A SECTIONAL AND 3A DISTRICT WRESTLING PLACE POINTS & ADVANCEMENT POINTS

As per the Wrestling Coaches Advisory Committee recommendation, eight person brackets will be used for ALL 1A & 2A sectional and 3A district meets, regardless of the number of wrestlers competing in a weight class. Wrestlers on championship brackets with less than 8 wrestlers and consolation brackets with less than 4 wrestlers will receive byes until they reach a bracket with an opponent.

Advancement points are awarded when a wrestler wins a match, **OR** receives a bye (*regardless of the outcome of the next match*), to advance to a bracket to compete against another wrestler. Two advancement points are awarded on the championship side of the bracket & one advancement point is awarded on consolation side of the bracket. No advancement points are awarded if a wrestler loses or advances to a bracket where there is no opponent to compete against, **except** when there are only five wrestlers on a bracket. In that case, the fifth place wrestler receives one advancement point for placing fifth, even though he never won a match. Even though wrestlers who receive byes are awarded advancement points, byes do **NOT** count as wins because the wrestler never intended to compete against anyone.

When two wrestlers who lost in the semifinals compete against each other to determine who will wrestle for true second place, the winner receives one advancement point for winning a consolation match and advancing to a bracket where there is another wrestler to compete against. If the match for true second does not take place because the wrestlers have already competed, the advancement point is still awarded because the wrestler did advance to wrestle another competitor. IHSAA rules simply state the match does not take place.

If there are fewer than 8 wrestlers on the 8-man bracket:

If there are seven wrestlers on the 8-man bracket, the wrestler losing in the first round and moving to the first-round consolation line with no opponent receives a bye, and one advancement point, to advance to the match for 5th & 6th places. The wrestler winning the first-round consolation match receives one advancement point to advance to the match for 5th & 6th places. The top six wrestlers receive place points.

If there are six wrestlers on the 8-man bracket, the two wrestlers losing in the first round and moving to the first-round consolation line with no opponent receive a bye, and one advancement point, to advance to the match for 5th and 6th places. All wrestlers receive place points.

If there are five wrestlers on the 8-man bracket, the wrestler losing his first round match is awarded 5th place points, **AND** one advancement point, even though he never won a match. All wrestlers receive place points.

If there are four wrestlers on the 8-man bracket, each wrestler receives a bye and two advancement points to advance to the semifinal bracket. All wrestlers receive place points.

If there are three wrestlers on the 8-man bracket, two wrestlers receive a bye and two advancement points to advance to the semifinal bracket and one wrestler receives two byes and four advancement points to advance to the finals. All wrestlers receive place points.

If there are two wrestlers on the 8-man bracket, both wrestlers receive two byes and four advancement points to advance to the finals. Both wrestlers receive place points.

TEAM SCORING

Six place team scoring (16, 12, 9, 7, 5, 3) is ALWAYS used in 1A & 2A sectional meets regardless of the number of wrestlers on a bracket. In the 1A/2A districts, points will be scored for the first three (3) places as follows, 14-10-7.

Team scoring must be contested within 30 minutes after the posting of final team scores in order for any consideration to be given to correcting team scores.

TEAM TIES AT SECTIONAL AND DISTRICT TOURNAMENTS

To determine the team winner of a sectional and/or district tournament which ends in a team tie for first place, the following criteria will be applied in the order listed:

- a. The team with the most individual champions will be declared the winner.
- b. The team with the most second-place winners will be declared the winner.
- c. The team with the most third-place winners will be declared the winner.
- d. The team with the most fourth-place winners will be declared the winner.
- e. The team with the most victories in head-to-head competition with other tied teams throughout the tournament will be declared the winner.
- f. The team with the most victories in the championship and consolation brackets will be declared the winner. (Do not count byes)

- g. The team that has accumulated the most advancement points throughout the tournament will be declared the winner.
- h. The team with the most pins, defaults, disqualifications and forfeits in the tournament will be declared the winner.
- i. The team with the most technical falls will be declared the winner.
- j. The team with the most major decisions will be declared the winner.
- k. If a tie still exists, a winner will be declared by a flip of the disk.

VIDEO TAPING MATCHES

Videotaping of matches is permissible provided viewing of the videotape by team personnel does NOT take place until the entire meet is over. The host management is NOT expected to provide electrical power.

WALL CHARTS

The IHSAA will furnish wall charts for each weight class to all sectional and district tournament managers, with the champion in each weight class receiving the wall chart.

WEIGH-INS

Weigh-ins for all sectional and district tournaments begin two hours before the scheduled starting time. Each wrestler who has certified their minimum weight class receives the two-pound growth allowance, as per NFHS rules. The tournament manager, or his/her designee, as well as the lead official, should be present at weigh-ins. When the weigh-ins are completed, the tournament manager, or his/her designee, should sign the weigh-in forms to verify their accuracy and make copies of the forms for all participating head coaches. For 1A and 2A district meets, there are no weigh-in sheets because wrestlers can only weigh in at the same weight in which they competed at sectionals. The host will either have a sheet printed out or use the brackets by weight class with names listed.

WRESTLING EXPENSE ALLOWANCE

A prerequisite for receiving any expense allowance from the IHSAA is that your school must travel to another town for the tournament participation.

Mileage for sectional and district wrestling:

- 1-4 participants = \$.48 per mile, one way
- 5-8 participants = \$.95 per mile, one way
- >8 participants = \$1.20 per mile, one way

Additional Expense Allowance

Sectional & District tournaments: \$6.00 per participant

01/17